

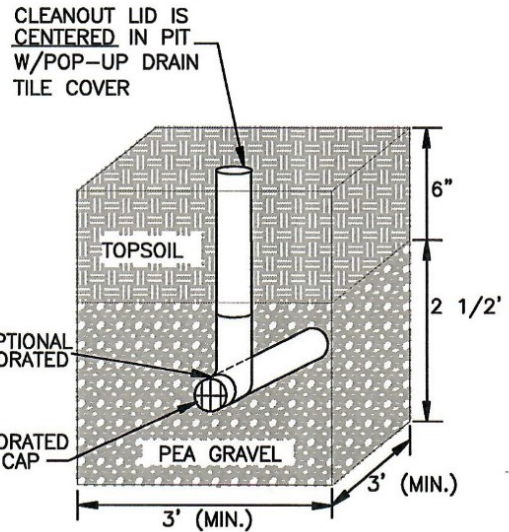

PROPERTY DISCHARGE PIT

VIEW FROM HOUSE

VIEW FROM STREET

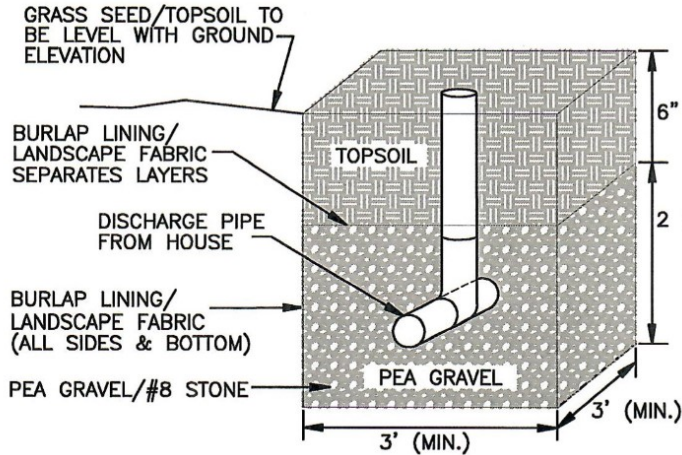

3'x3'x3' (MIN.) DRY WELL TO BE LINED WITH BURLAP LINING/
LANDSCAPE FABRIC INCLUDING A 3'x3' BURLAP TOP FLAP.

FILL HOLE 2 1/2' DEEP WITH PEA GRAVEL
DISCHARGE PIPE INTO PEA GRAVEL LAYER AND
COVER PEA GRAVEL WITH BURLAP FLAP.

FILL REMAINING 6" OF DRY WELL WITH TOPSOIL.
LEVEL WITH THE EXISTING GROUND ELEVATION.

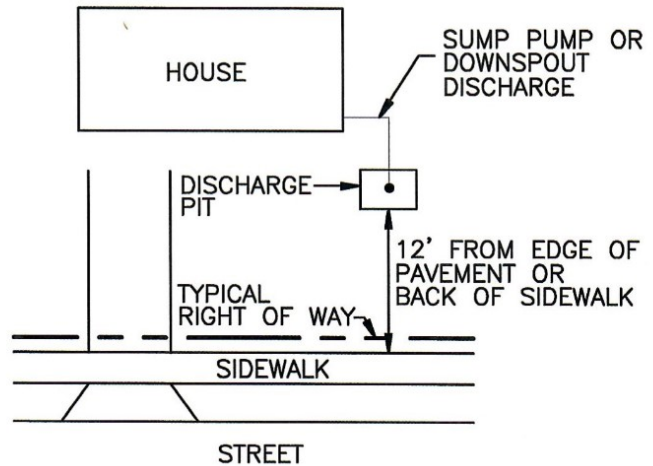
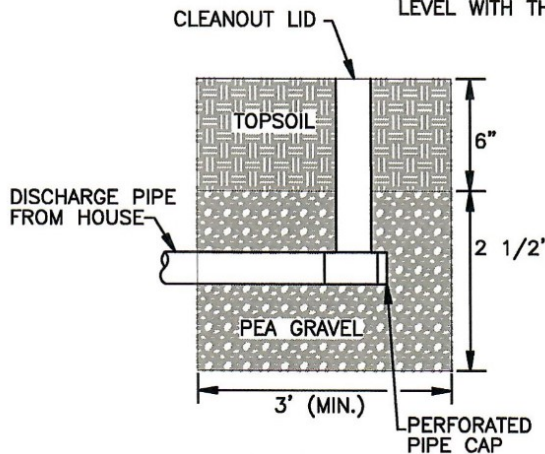

VIEW FROM SIDE

TYPICAL PLAN VIEW